	<p>The Effect of Short Link Resonance on the NEXT and PSNEXT Performance of 7m Channels</p>
<p>Data Communications Competence Center</p>	<p>DCCC02082102R1 July 11, 2007</p>

Test Summary

This report compares the results of NEXT and PSNEXT testing for seven meter Category 6 channels. Channels consisting of components from five connector manufacturers and five cable manufacturers were evaluated against the requirements of ANSI/TIA/EIA-568-B.2-1-2002. These results are compared to those of the Berk-Tek/Ortronics NetClear^{GT2} solution. All testing was performed using commercially available handheld testers.

Background

It is commonly assumed that the worst-case cabling system performance occurs on channels that consist of four connectors at a length of 100 meters. Contrary to this assumption, NEXT and PSNEXT performance margins are worse on short channels. The difference in performance of these short channels can result in failures in the field, more time spent on testing and troubleshooting and higher installation costs.

The short link phenomenon was first observed with Category 5 cabling. Also known as “short link resonance” it is caused by accumulative signal imbalances and additive noise that comes from two connectors that are in close proximity to each other.

Short link resonance was most apparent in installations with less than 15 meters (49 feet) between connectors. Since then, improvements were made in the design of Category 5 components. This helped to minimize the problem. In addition, manufacturers have incorporated minimum link distance requirements or specific patch cable lengths into their warranty programs.

Short link resonance has become an issue again with the introduction of Category 6 cabling systems and components. At this time, some manufacturers have not refined their components well enough to ensure short channel performance that meets Category 6 requirements.

However, systems such as the Berk-Tek/Ortronics NetClear solutions are tuned to meet the center TIA target connector values¹. Jacks, patch panel and patch cord terminations, along with the performance of the horizontal cabling are tuned to this center target to provide maximum performance.

Equipment

Field Test Unit 1

- Manufacturer: Fluke DSP-4100 and DSP-4100SR
- Adapter: DSP-LIA013
- Software: Standards version 4.9 Software version 4.8

¹ “Cabling System Selection, A Product and System Approach,” R. Aekins and G. Lafontaine

Field Test Unit 2

- Manufacturer: Microtest OMNIScanner and OMNIRemote
- Adapter: CHAN 5/5e/6
- Software: V06.00

Test Setup

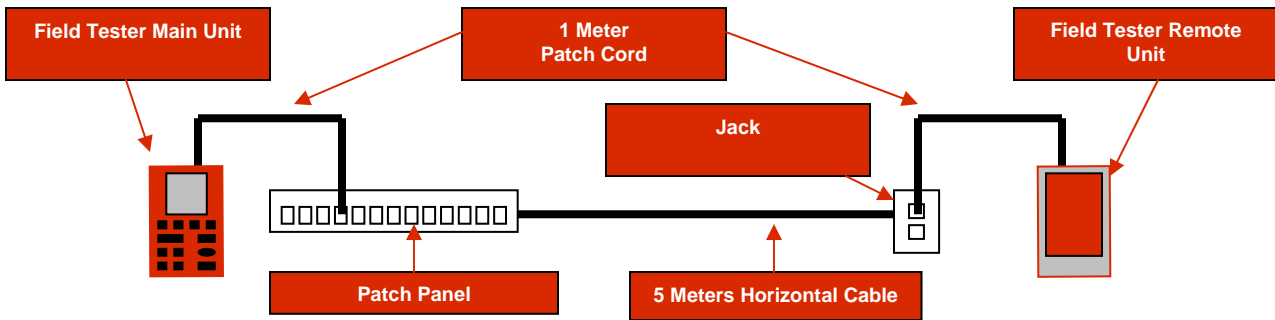

Test Results

Components from five connector manufacturers and five cable manufacturers were assembled into seven meter channels as shown in the Test Setup section of this report. To maintain the anonymity of the manufacturers they are numbered one through five. Connector manufacturers are mated with cable manufacturers per commercial marketing relationships.

Results for NEXT and PSNEXT testing are shown in Table 1. The values represent the worst-case margin across the test frequency range of 1 Mhz to 250 Mhz. Channel tests are evaluated against the requirements of ANSI/TIA/EIA-568-B.2-1-2002.

Test Number	Connector Manufacturer	Horizontal Cable Manufacturer	Pass/Fail	Tester 1		Tester 2	
				NEXT (dB)	PSNEXT (dB)	NEXT (dB)	PSNEXT (dB)
Test A	Connector 1	Cable 1	Fail	-0.9	0.5	-1.7	-0.9
Test B	Connector 2	Cable 3	Pass	5.7	7.4	5	5
Test C	Connector 2	Cable 5	Pass	1.9	3.5	1.1	1.5
Test D	Connector 3	Cable 5	Pass	4.3	5.4	1.3	2.7
Test E	Connector 4	Cable 2	Fail	-1	-1	-2.2	1.4
Test F	Connector 5	Cable 4	Fail	-0.7	1.4	1.9	1.9
Berk-Tek/Ortronics NetClear ^{GT2}			Pass	7.4	9	5.6	4.9

Results from two field testers are represented in the data.

- Both Test A and Test E failed NEXT using both field test units.
- Using tester 1, three of the six competitive tests failed Category 6 NEXT requirements while one test failed PSNEXT. One PSNEXT test was marginal passing by only 0.5 dB.

- Results for Tester 2 show that two of the six competitive samples failed NEXT requirements while one sample failed Category 6 PSNEXT requirements.
- Test E failed PSNEXT with Tester 1 while Test A failed PSNEXT with Tester 2. Of the competitive samples tested,
- Test B passed with the largest margin.
- The Berk-Tek/Ortronics NetClear^{GT2} sample exhibited the highest margin of any channel tested.

There is a difference between the values measured by Tester 1 and Tester 2. Chart 1 through 4 contains swept frequency NEXT and PSNEXT data for Tester 1 and Tester 2. Evaluating the traces reveals that there is some offset between the data from Tester 1 and Tester 2. Results for Tester 2 show lower margins on average than Tester 1. This is most evident at frequencies below 150 MHz. This occurs for both NEXT and PSNEXT tests. Although this data is representative of what would be measured in an actual installation, the limited number of tests does not allow any definite observations to be made concerning measurement differences between handheld testers.

Chart 1: Field Tester 1 Worst Case Near-End Crosstalk

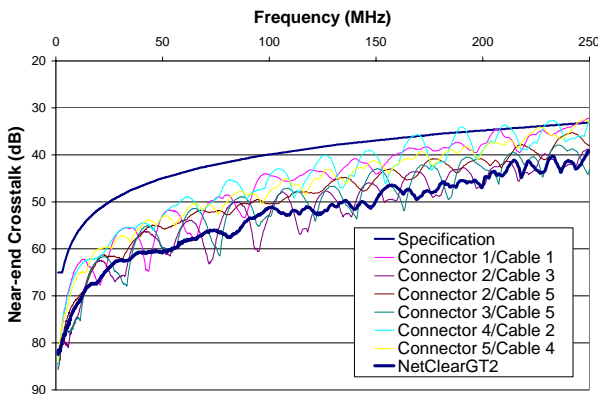

Chart 2: Field Tester 1 Worst Case Power Sum Near-End Crosstalk

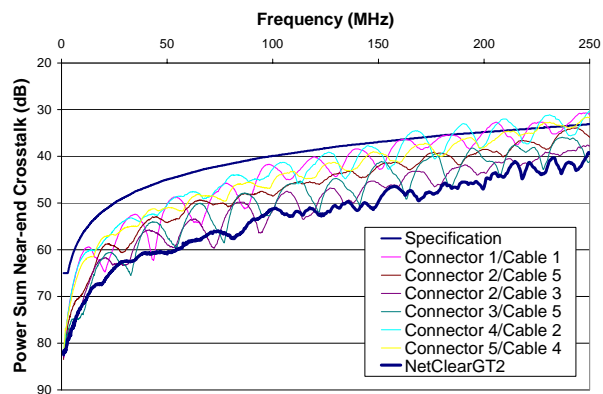

Chart 3: Field Tester 2 Worst Case Near-End Crosstalk

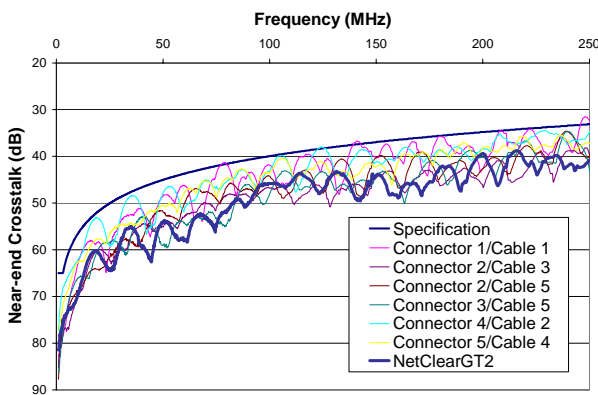
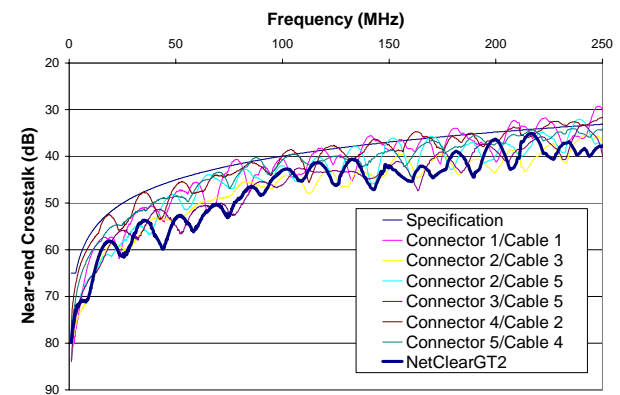

Chart 4: Field Tester 2 Worst Case Power Sum Near-End Crosstalk



Conclusion

Short link resonance was a problem that was commonly experienced with Category 5 cabling systems. This problem was solved through improvements in connecting hardware and specifying the minimum distance between connectors in a channel. Although Category 6 cabling system designers are aware of this phenomenon, it is again a problem for some manufactures.

Several of the competitive solutions failed NEXT requirements.

The data shows the importance of benchmarking short links in addition to the more common 100-meter links that many manufacturers consider “worst case”. In a study performed by Ortronics², it is observed that NEXT margin, when compared to margin measured on a network analyzer, decreases with channel length. Margin decreases steadily when the channels are below 15 meters; degrade more steeply below 10 meters and drastically below 7 meters.

The Berk-Tek/Ortronics NetClear^{GT2} solution had the highest margin of any of the solutions tested.

As seen in the results of this testing, there are also differences between the test results obtained from different field testers. Although the test sample size is small, there is a visible offset between the results. More work is required to investigate the causes of the differences between the field testers and their correlation to laboratory network analyzers.

Manufacturers’ guarantees and warranties vary. It is important to specify a solution that offers strong 100-meter margins and guarantees compliance to Category 6 channel requirements at any length. The very high margins measured for the NetClear solution shows that the NetClear^{GT2} solution has the margin necessary to support any standard channel length, even those less than 15 meters.

² “Short Links and Channels,” R. Aekins and G. Lafontaine

Data Communications Competence Center

Nexans' Data Communications Competence Center, located at the Berk-Tek Headquarters in New Holland, Pennsylvania, focuses on advanced product design, applications and materials development for networking and data communication cabling solutions. The Advanced Design and Applications team uses state-of-the-art, proprietary testing and modeling tools to translate emerging network requirements into new cabling solutions. The Advanced Materials Development and Advanced Manufacturing Processes teams utilize sophisticated analytical capabilities that facilitate the design of superior materials and processes. The Standardization and Technology group analyzes leading edge and emerging technologies and coordinates data communication standardization efforts to continuously refine Nexans' Technology Roadmap. An international team of experts in the fields of cable, connectors, materials, networking, standards, communications and testing supports the competence center. The competence center laboratories are a part of an extensive global R&D network that includes eight competence centers, four application centers and two research centers dedicated to advanced technologies and materials research.