



Power and Data Separation Test Results Using Conduit and Corrugated Power Cables

Data Communications Competence Center

DCCC03081302
June 29, 2007

Test Summary

The purpose of this test was to determine the interference to Gigabit Ethernet traffic on LM1000 Category 6 UTP cable caused by EFT pulses on corrugated cable or power cable within a conduit at the separation distances of zero, one or two inches.

The results show that having the power cable in conduit provides the data cables significant protection from errors. At zero separation, the corrugated cable test generated data errors at a significantly lower voltage-level than with the power cable in a conduit, but less than previous tests with the power cable in a plastic raceway. The corrugated power cable at one inch and two inch separation from the data cable did show a significant level of protection - close to the level found with the power cable in a standard-conduit.

Background

The EFT method is used within the Data Competence Center (as well as other well-known test facilities such as The Tolly Group) to evaluate the noise immunity of UTP. It has also been used to determine whether separation of power and data cables is necessary while transmitting Fast Ethernet or Gigabit Ethernet signals.

Previous evaluations have used power cable in a plastic raceway or fastened on a flat surface at the required distances from data cable. This is the first evaluation where the shielded power cables were used.

Test Setup

The hardware used in the trials was as follows:

- Spirent SmartBits® 2000 Multi Performance Analysis System containing two Model GX-1420B Gigabit Ethernet modules. The test consisted of 1400 byte frames with a 0.16 μ s inter-packet gap. The cards were run in continuous packet mode at full duplex.
- Haefley EFT Pulse Generator, PHV 41.2 High Voltage Unit, P90.1 Control Unit and Clamp
- Cisco Catalyst 3550 switch
- Three 100-meter, four connector channels
 - Cable:
 - One Berk-Tek LANmark-1000 Category 6 CMP Blue
 - One Berk-Tek LANmark-1000 Category 6 CMP Grey
 - One Berk-Tek LANmark-1000 Category 6 Yellow
 - Connectivity:
 - Jack: Ortronics Clarity⁶ Category 6
 - Patch Cables: Ortronics Clarity⁶ Category 6
 - Patch Panels: Ortronics Clarity⁶ Category 6

Conduit and Corrugated Power Cable Data Separation Test	DCCC03081302	June 29, 2007
---	--------------	---------------

- 90 meters of ½ inch EMT conduit with 3 #12 THHN conductors and a 20 ampere, 120 volt duplex receptacle at each end.
- 90 meters of 12/2 MC cable with 20 ampere, 120 volt duplex receptacle at each end.

The EFT test is used to evaluate the effect of a power cable on a nearby data cable. Using the Haefley unit, electrical fast transient (EFT) pulses are generated with a normal current onto the power cable. Gigabit Ethernet data packets are transmitted along the LAN cable, which is located a controlled distance from the power cable. The number of data packet errors is monitored at each EFT pulse voltage.

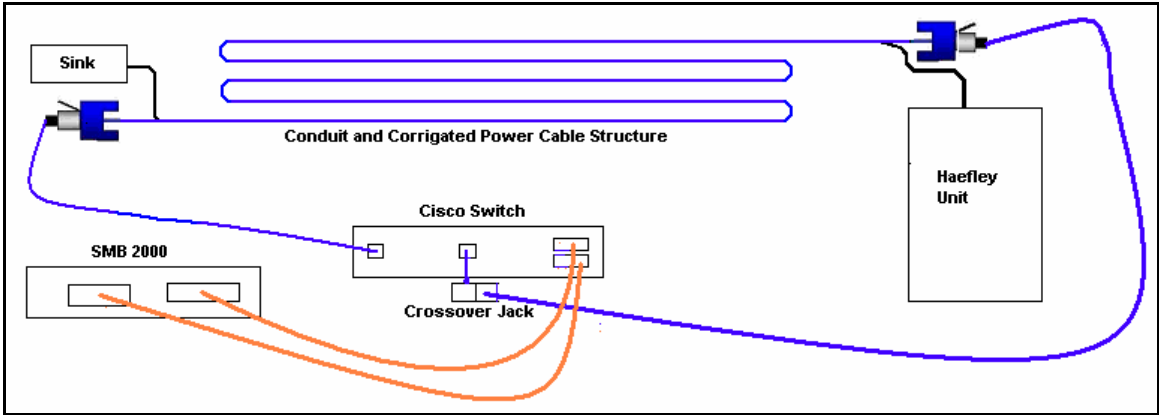

Figure 1: EFT Test Setup with SmartBits Data Generation



Figure 2: Haefley Generator and Cisco Switch



Figure 3: Haefley Generator and heat sink.

Each LM1000 cable was installed one at a time on the shelf structure first at zero separation, then again at one and two inch spacing from the data cable.

The Haefley EFT Pulse Generator was connected to either the corrugated power cable or the power cable within the conduit with a heater connected to the other end as a sink. The voltage level of the EFT pulse was constant for each 300-million packet test, with the voltage increasing in each consecutive test.

A SmartBits fiber card sent and received 1400 octet packets with 0.16 microsecond inter-packet gap to the Cisco switch through a MMF link. The data traffic passed through the Cisco switch onto the test cable channel, back to the Cisco switch and then onto fiber cable returning to a second Smartbits card.

Errors were seen as dropped packets, since the Cisco switch treats CRC errors by dropping the packets.

Test Results

Corrugated Cable Results

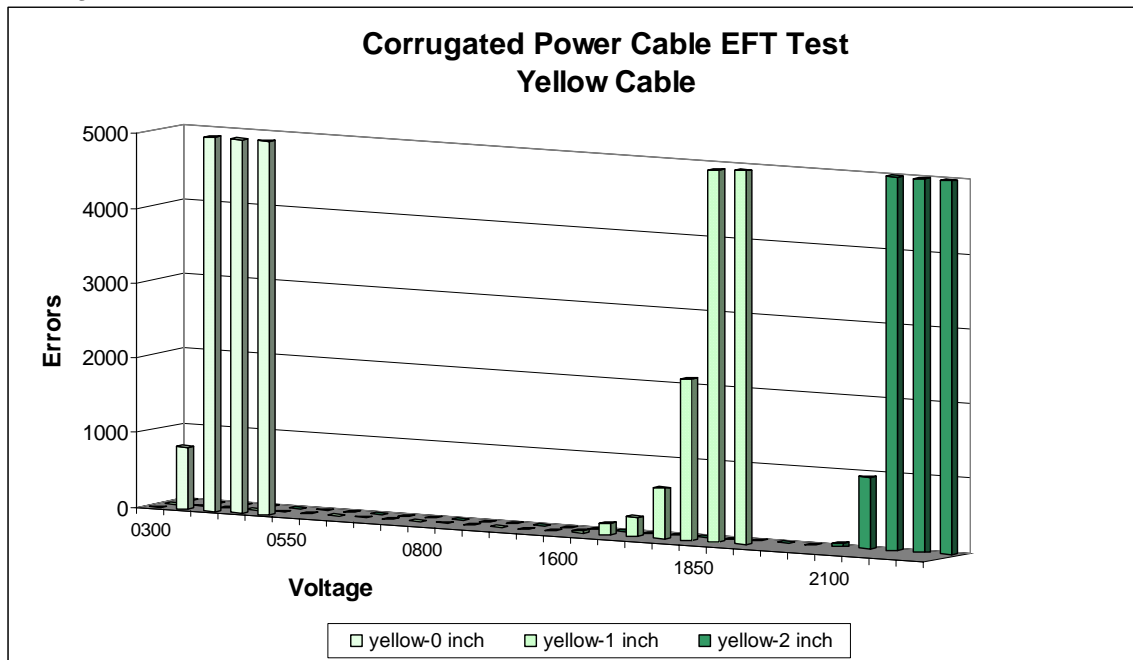

Figure 4: Results of all voltages for the yellow data cable with the corrugated power cable.

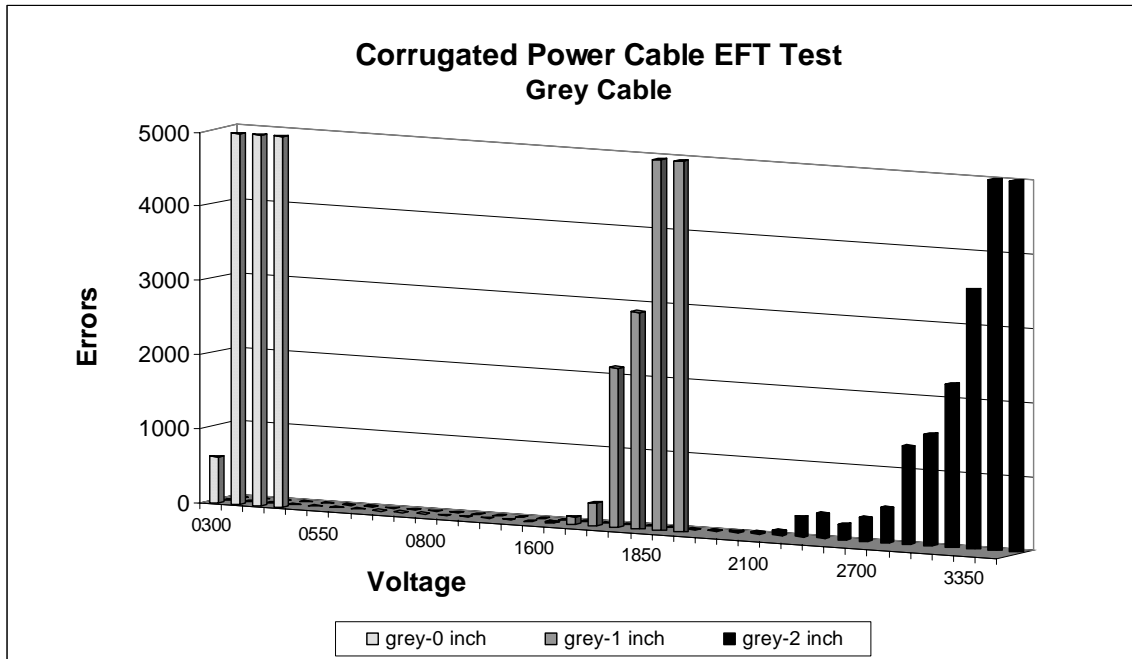

Figure 5: Results of all voltages for the grey data cable with the corrugated power cable.

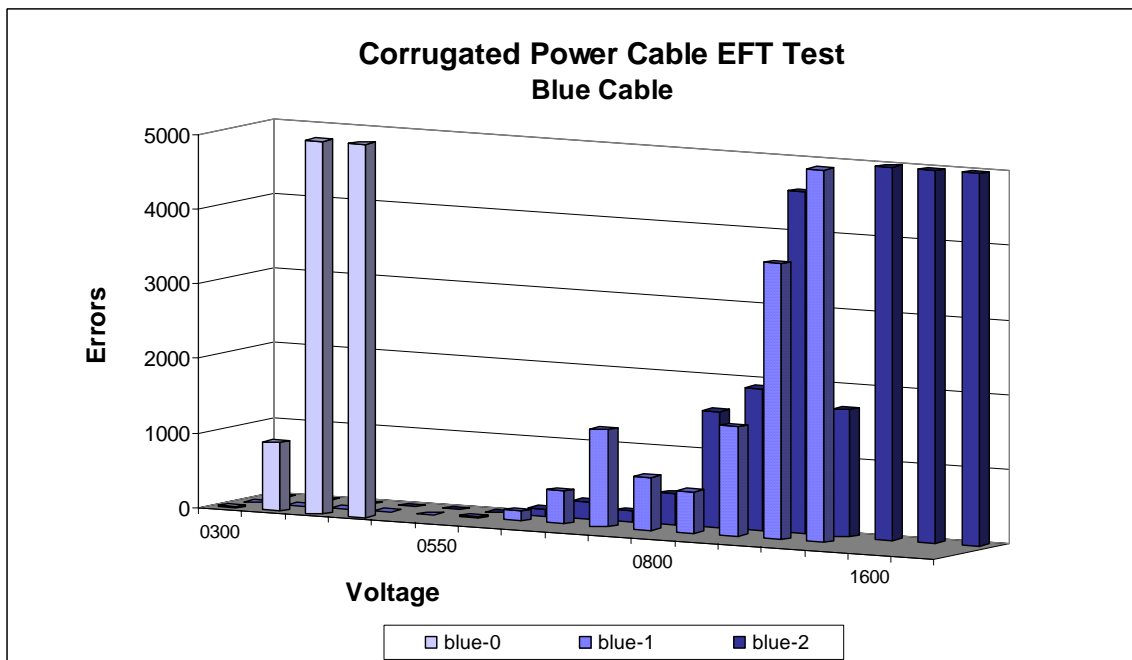

Figure 6: Results of all voltages for the blue data cable with the corrugated power cable.

In Figures 4-6, the results are graphed at each of the three distances from the power cable.

Observations from these charts:

- At zero separation, errors are generated at 350-volts. The LM1000 cable was previously tested with power cable at zero separation in a plastic raceway and demonstrated errors beginning at 500 volts. This indicates that zero separation affects the data cable more than the added shielding helps it.

- For two of the cables (grey and yellow) tested, as the distance between the corrugated power cable and the data cable increased to one and two inches, the threshold voltage increased significantly.
- The blue cable showed a significant increase in the voltage where errors are seen when the distance is increased from zero to one inch, but when the distance was increased again, there was very little increase in the voltage where errors were seen. This anomaly may be due to grounding issues or the placement of the cable.

Power Cable in a Conduit Results

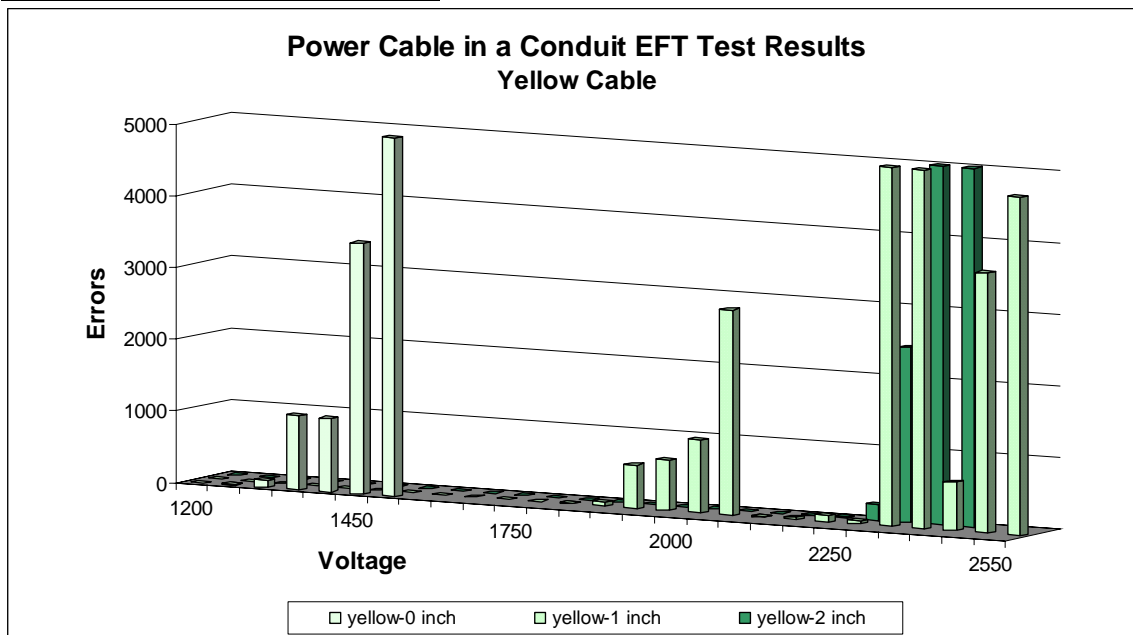

Figure 7: Results of all voltages for the yellow data cable with the power cable in solid conduit.

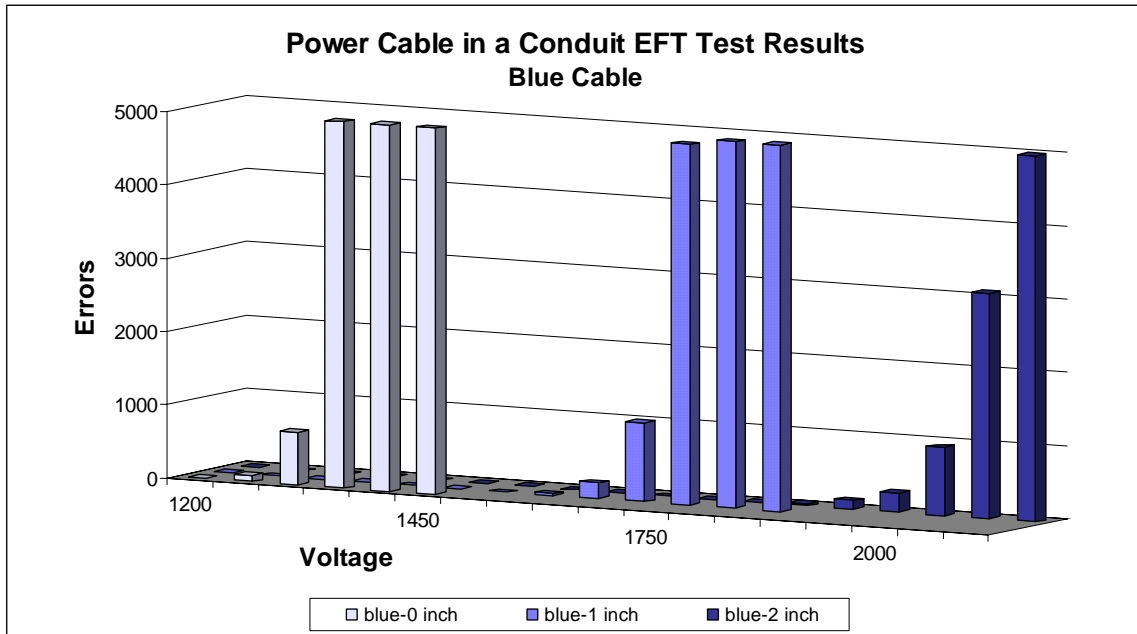

Figure 8: Results of all voltages for the blue data cable with the power cable in solid conduit.

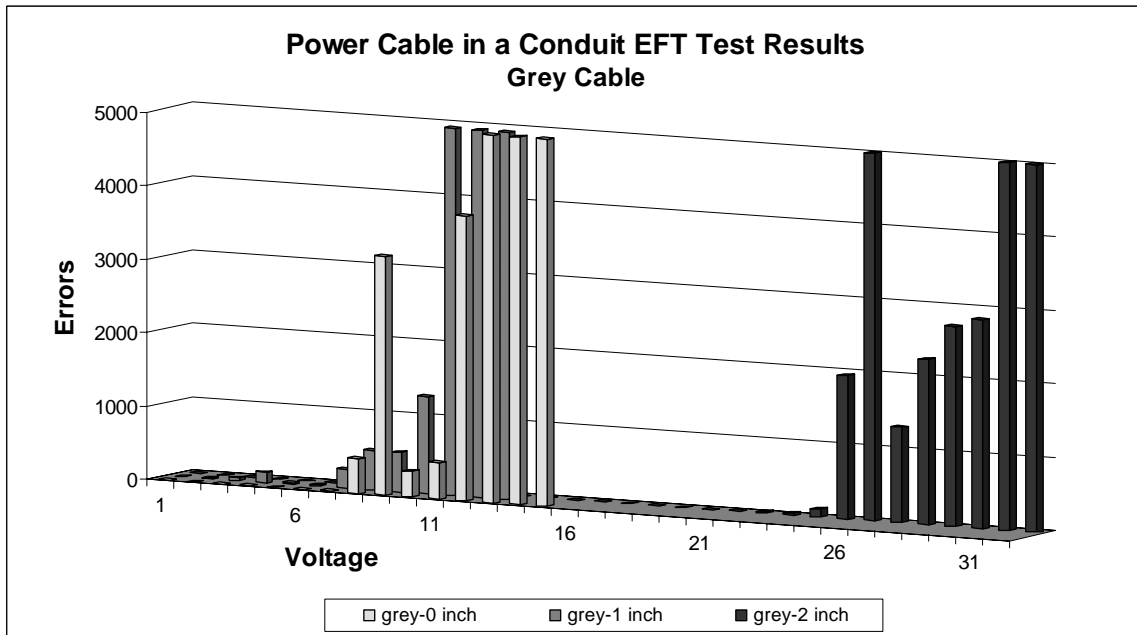

Figure 9: Results of all voltages for the yellow data cable with the power cable in solid conduit.

In Figures 7-9, each individual cable has results shown at the zero, one and two-inch separations.

Observations from the chart:

- The voltage where errors start to occur at zero separation between the conduit and the data cable is in the 1400 to 2250 volt range.

- As was observed in the corrugated power cable tests, the increase of distance between the conduit and the data cable correlates to a significant increase in the voltage where errors occur.
- The grey cable shows an anomaly where the zero separation between the conduit and the data cable shows the occurrences of errors beginning at a higher voltage than the one-inch separation. This behavior is currently under investigation.
- The yellow cable shows a significant difference in voltages where errors began at zero and one inch separation. The level where the errors increase to above 3000 errors for these same separations is at the 2550 voltage level.

Error Levels

In Table 1, the voltages are listed for each LM1000 cable and each separation distance. The averages of the cables clearly show the advantage of power cable in a conduit for zero separation. As the separation is increased to one and two inches, the advantage remains to a lesser degree.

Voltage of First Errors				
Cable	Separation	Corrugated	Conduit	Difference
Blue	0	400	1250	850
	1	1900	1600	-300
	2	2000	1750	-250
Grey	0	350	2250	1900
	1	1450	1950	500
	2	2750	3350	600
Yellow	0	400	1500	1100
	1	1600	2000	400
	2	2500	2400	-100
Average	0	383	1667	1283
	1	1650	1850	200
	2	2417	2500	83

Table 1: Voltages of the first occurrences of errors

To view clearly the point at which errors occur using the two methods of shielding, the voltages of the first occurrences of errors is correlated to the separation. Figures 10 and 11 show the relationship.

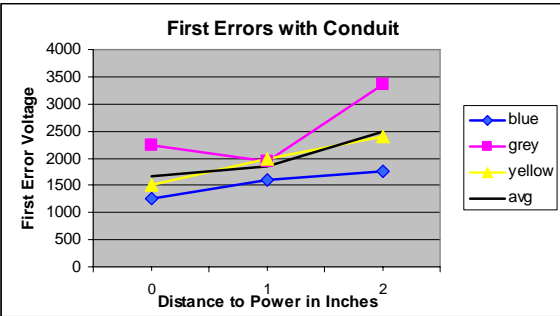

Figure 10: Voltage of Conduit First Errors

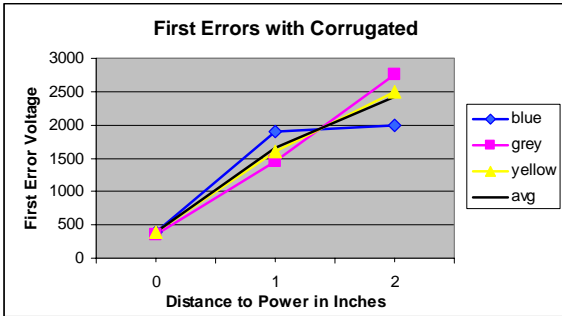

Figure 11: Voltages of Corrugated First Errors

Figure 12 shows the voltage differences between the conduit results and corrugated results. The advantage of conduit at zero inch averages to 1250 volts, while the difference drops to 200 for one-inch and 50 for two-inches.

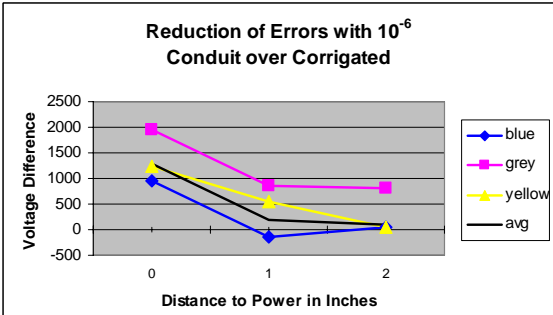
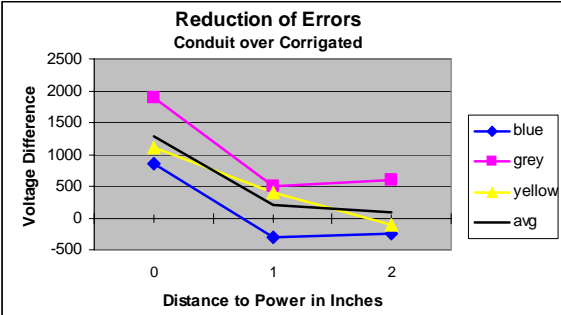

Figure 12: Advantage at First Occurrence of Errors Figure 13: Advantage at 10⁻⁶ Errors

In Figure 12, the advantage of power cable in a conduit is clearly seen at zero separation. The one and two inches average to a slight positive advantage. Figure 13 gives the reduction of errors at 10⁻⁶ errors, which supports the averages found in Figure 12 at a slightly higher error rate.

Individual Cable Analysis

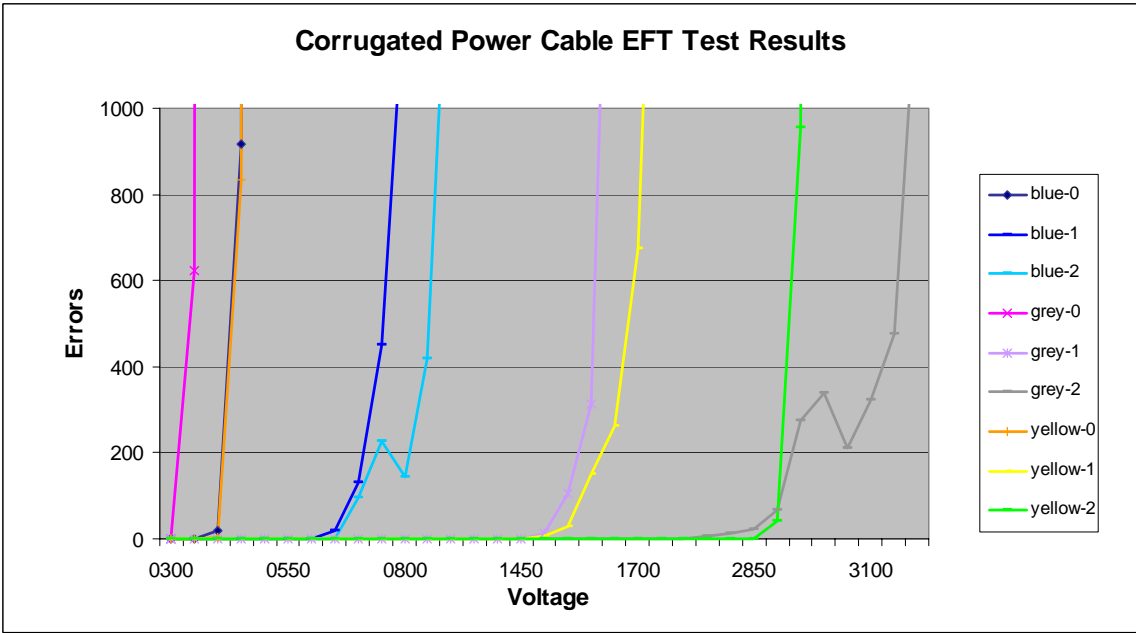

Figure 14: Results of all voltages for corrugated power cable up to 1000 errors.

By looking at the test results in Figure 14, it is clear that increasing the distance from zero to one and then to two inches, significantly impacts the voltage where errors occur for both the grey and yellow cables. Also, even though the first increase in distance acts similarly, the second increase only slightly raised the voltage of the first errors.

In the blue and grey cables with two-inch separation, it is observed that there is a dip in the number of errors as the voltage levels are increased. This is also seen in results from the conduit tests.

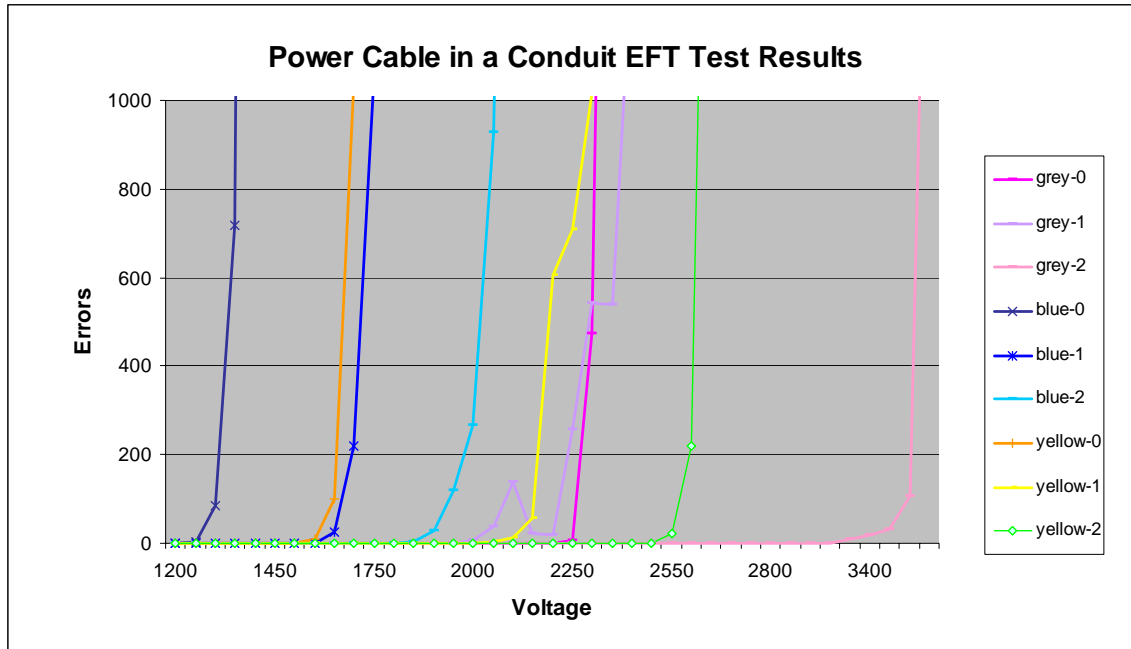

Figure 15: Results of all voltages for conduit power cable up to 1000 errors.

Figure 15 illustrates that the blue cable has regular increases in the voltages of the first errors, unlike the results with corrugated cable. This figure also shows that the grey cable at one-inch has lower voltages of first errors than the grey cable at zero separation.

Conclusions

The conclusion that can be drawn from these tests is that the corrugated power cable with EFT pulse spikes at zero separation causes the highest level of errors to nearby data cables. At the one and two-inch levels, the corrugated power cable provides slightly less protection than the power cable in a conduit.

There are several anomalies in the results from these trials. It is possible that there were grounding issues, which may have taken part. For the majority of the testing, the increase in distance significantly improved the threshold voltage where errors were detected.

Table 1: Definitions of Acronyms	
Abbreviation	Description
CAT5	Category 5 cable
CAT6	Category 6 cable
CAT6e	Category 6 enhanced cable
CRC	Cyclic Redundancy Check
EFT	Electrical Fast Transient
HVAC	Heat, Ventilation and Air Conditioning
IEEE	Institute of Electrical and Electronics Engineers
LAN	Local Area Network
NIC	Network Interface Card
PER	Packet (Frame) Error Rate
UTP	Unshielded Twisted Pair

Data Communications Competence Center

Nexans' Data Communications Competence Center, located at the Berk-Tek Headquarters in New Holland, Pennsylvania, focuses on advanced product design, applications and materials development for networking and data communication cabling solutions. The Advanced Design and Applications team uses state-of-the-art, proprietary testing and modeling tools to translate emerging network requirements into new cabling solutions. The Advanced Materials Development and Advanced Manufacturing Processes teams utilize sophisticated analytical capabilities that facilitate the design of superior materials and processes. The Standardization and Technology group analyzes leading edge and emerging technologies and coordinates data communication standardization efforts to continuously refine Nexans' Technology Roadmap. An international team of experts in the fields of cable, connectors, materials, networking, standards, communications and testing supports the competence center. The competence center laboratories are a part of an extensive global R&D network that includes eight competence centers, four application centers and two research centers dedicated to advanced technologies and materials research.