	Cabling Infrastructure Test Gigabit Ethernet with Gigabit Switches
Data Communications Competence Center	DCCC05100702R1 June 29, 2007

Test Summary

This report is the Cabling Infrastructure Test for Gigabit Ethernet tests using the Gigabit switches. The result of the LM2000 channels is that it performs with zero errors at all longer lengths. The LM1000 and LM350 have minimal errors at 388 ft when used with Clarity patch cords. The results show that the quality of the cable and patch cords effect the distance that Gigabit Ethernet can be carried over a channel without errors.

Background

Installed cabling at longer than standard lengths is an ongoing practice. An evaluation was requested to test longer length cabling channels using Gigabit switches and Standard category 5 patch cords for category 5e cabling and Clarity® patch cords for category 6 cabling. The results of this study will assist in decisions of where existing cabling needs to be updated and what cable to use for new installations.

TIA standards specify performance of cabling channels at a length of 100 meters, which is 328 feet that includes the total length of cable and patch cords. The horizontal cable lengths of 320, 370 and 420 feet were installed and two – 9 foot patch cords for each horizontal length were used in this evaluation to determine the limits beyond the standards that Gigabit Ethernet data traffic is received with a minimal number of errors.

Test Set-up

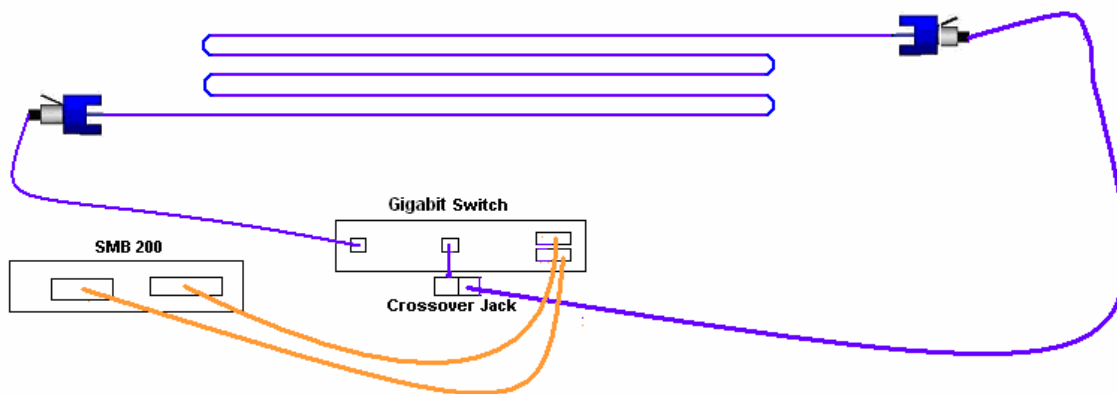

Figure 1: Test Setup Diagram

The above diagram represents the test setup used to evaluate the different lengths of cable. The Gigabit Ethernet traffic is generated by SmartBits and is connected through the Gigabit switch to provide a real-world data signal.

The hardware used in the trials was as follows:

- Spirent SmartBits® 2000 Multi Performance Analysis System containing two Model GX-1420B Gigabit Ethernet modules. The test consisted of 64 or 512 byte

frames with a 0.128 μ s inter-frame gap. The cards were run in continuous packet mode at full duplex.

- Gigabit switches were used in this testing.
- The following two connector channels:
 - Cable:
 - HyperPlus category 5e cable, lengths of 313, 338, 388 and 438 feet.
 - LM350 category 5e cable, lengths of 313, 338, 388 and 438 feet.
 - LM1000 category 6 cable, lengths of 313, 338, 388 and 438 feet.
 - LM 2000 category 6 cable, lengths of 313, 338, 388 and 438 feet.
 - Connectivity:
 - Patch Cables:
 - Category 5 patch cables
 - Ortronics Clarity® 5e patch cables
 - Ortronics Clarity® 6 patch cables
 - Connectors:
 - Ortronics Clarity® 5e Patch Panels
 - Ortronics Clarity® 6 Patch Panels

Test Results

The following results clearly demonstrate that Gigabit Ethernet data traffic has fewer errors over category 6 channels than the category 5e channels when transmitting over longer than standard lengths. In addition, the results demonstrate that channels with the Clarity® 5e patch cords have fewer errors than channels with the category 5 patch cords for the majority of longer length channels.

Table 1: Gigabit Ethernet Results using the Gigabit Switches

Cable Type and Sample	Patch Cords	Packet Length	Channel Lengths					
			313 ft	338 ft	388 ft		438 ft	
			Errors	Errors	Errors	% err	Errors	% err
HyperPlus 5e	1	Cat 5	0	0	16,064,338	.2869%	235,993,581	4.2142%
	1	Clarity	0	0	15,500,397	.2768%	267,791,881	4.7820%
	2	5e	0	0	15,710,618	.2805%	427,699,421	7.6375%
LM350	1	Cat 5	0	0	2,508,329	.2787%	1,149,720,111	127.746%
	1	Clarity	0	0	2	2.2E-10%	214,669,169	23.8521%
	2	5e	0	0	2	2.2E-10%	18,164,280	2.0183%
LM1000	1	Clarity	0	0	0	0%	108,923,686	1.9451%
	2	6	0	0	2	3.6E-10%	15,900,630	.2839%
LM2000	1	Clarity	0	0	0	0%	0	0%
	2	6	0	0	0	0%	0	0%

The packets transmitted onto the LM350 channel are 512 bytes, which is eight times the length of the packets used for all other channels. This may have inflated the percentages of frame errors due to the larger number of bytes lost when an error occurs.

Note: For the longer lengths, the two channels of LM350 and the two channels of LM1000 have error rates that differ by one order of magnitude. During testing, it was determined that some ports of the Gigabit switches were stronger than others. The difference in errors of the two channels could very easily be caused by strong and weak ports over the extraordinary distance of the channel.

Conclusions

The results clearly show that LM2000 is capable of performing with no errors at the longest length for Gigabit Ethernet data traffic. The LM1000 and LM350 perform well with Clarity patch cords on the 388 ft channels. The results at this time clearly demonstrate that the quality of the cable can significantly reduce the number of errors on longer than standard channel lengths and that the quality of the patch cord also has a strong effect in reducing errors.

Data Communications Competence Center

Nexans' Data Communications Competence Center, located at the Berk-Tek Headquarters in New Holland, Pennsylvania, focuses on advanced product design, applications and materials development for networking and data communication cabling solutions. The Advanced Design and Applications team uses state-of-the-art, proprietary testing and modeling tools to translate emerging network requirements into new cabling solutions. The Advanced Materials Development and Advanced Manufacturing Processes teams utilize sophisticated analytical capabilities that facilitate the design of superior materials and processes. The Standardization and Technology group analyzes leading edge and emerging technologies and coordinates data communication standardization efforts to continuously refine Nexans' Technology Roadmap. An international team of experts in the fields of cable, connectors, materials, networking, standards, communications and testing supports the competence center. The competence center laboratories are a part of an extensive global R&D network that includes eight competence centers, four application centers and two research centers dedicated to advanced technologies and materials research.