	Using Category 6 Cabling to Improve Gigabit Ethernet Reliability Using Non-optimum Transceivers
Data Communications Competence Center	DCCC02051701R3 June 29, 2007

Test Summary

This test report compares the number of Cyclic Redundancy Check (CRC) errors generated over category 5e and category 6 cabling systems when using a Gigabit Ethernet transceiver that exhibits weak receiver characteristics. The testing shows significant reductions in the number of CRC errors when replacing a category 5e cabling channel with a category 6 cabling channel.

Background

In testing performed at Nexans' Data Communications Competence Center located in New Holland, Pennsylvania, eight laboratory-grade Gigabit Ethernet transceiver modules were utilized to perform network testing. During the course of the project, using the same category 5e cabling system, differences in the number of CRC errors generated by various transceivers of the same make and model were observed. For this evaluation, a module was chosen that exhibited non-optimum receiver performance as well as two transceivers that exhibited better performance when compared to the other Gigabit Ethernet transceiver modules.

The performance of the non-optimum transceiver module was verified by comparing the results to testing performed with the other Gigabit Ethernet transceiver modules. These tests were conducted multiple times to confirm the consistency and accuracy of the results. Data pertaining to the non-optimum transceiver module is labeled "Test Series B" in the test results section of this report.

Data for the evaluation of the two other modules is summarized in the test data as "Test Series A". All testing was performed on a category 5e channel and then repeated using a category 6 channel to observe if there were any differences in the number of CRC errors.

One function of the Spirent SmartBits® 2000 unit used in the measurements is to monitor the number of CRC errors that are detected. Ethernet packets contain information about the sending and receiving station, the data being transmitted, along with other information. As part of the verification process, the sending station generates a CRC checksum. The receiving station confirms the checksum and makes a judgment if the packet was received intact. If the checksum is not correct, the packet is discarded and must be retransmitted. The presence of CRC errors may indicate a network problem that must be addressed.

Equipment

- Spirent SmartBits® 2000 Multi Performance Analysis System with Model GX-1420B Gigabit Ethernet modules
 - 64 bit packets, time burst, full duplex, 1 hour duration
- 100 meter, 3 connector cabling channel
 - *Category 5e* – Berk-Tek LANmark-350 cable with Ortronics CAT 5e connecting hardware

Category 6 - Berk-Tek LANmark-1000 cable with Ortronics GigaMo+ connecting hardware

Test Setup

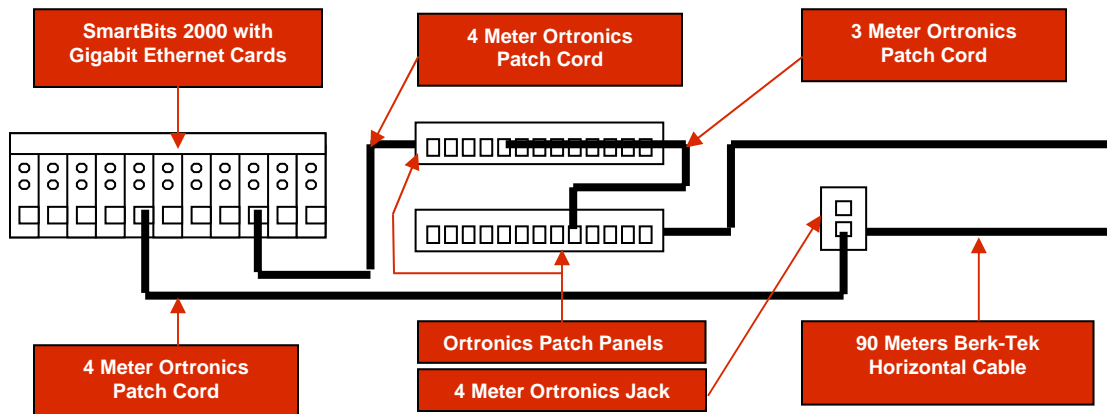

Test Results

Chart 1 compares the number of CRC errors detected by the SmartBits® 2000. The chart shows differences in the number of CRC errors generated using category 5e cabling and category 6 cabling.

The results of Test Series B show that a total of 543 CRC errors were counted over category 5e cabling. The number of errors was reduced to 39 when the testing was repeated over category 6 cabling. An average of 136 CRC errors per test were measured using category 5e cabling. Category 6 cabling reduced the average number of errors to 10 per test.

In Test Series A, the summarized data shows two CRC errors when using category 5e cabling and zero errors with category 6.

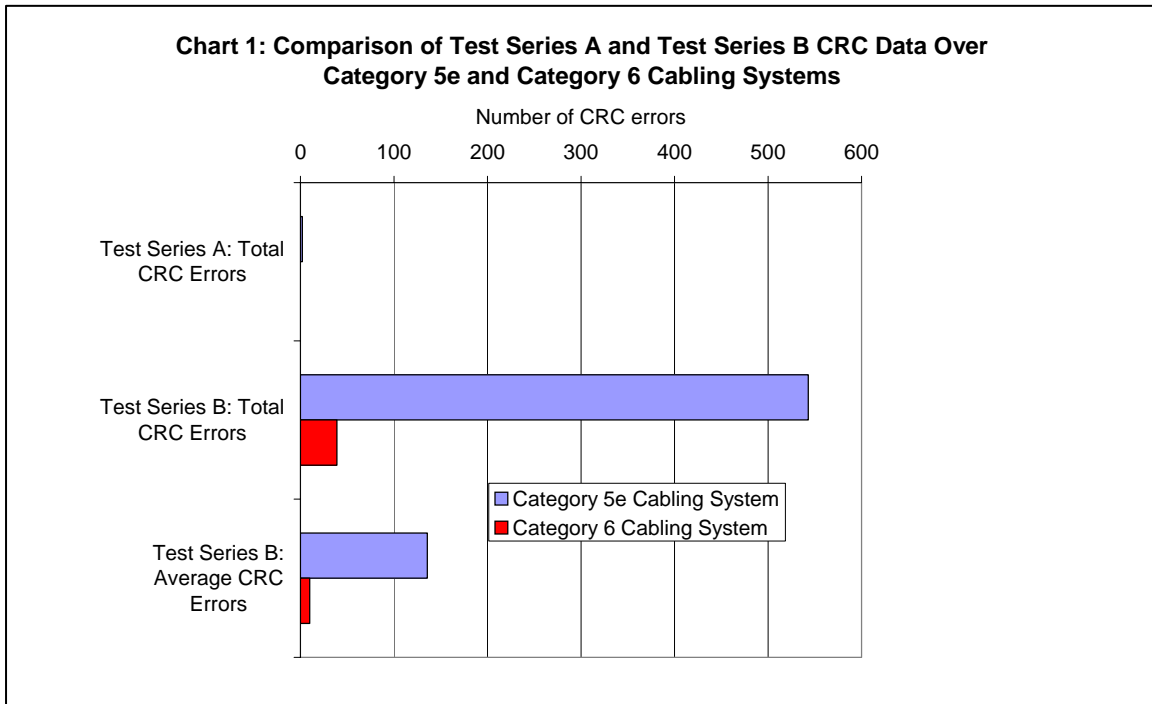

Conclusion

A common assumption is that all Ethernet transceivers are the same. This evaluation demonstrated that there is variability in the characteristics of these units--even among transceivers of the same manufacturer and model number. Although Gigabit Ethernet transceivers are manufactured to exacting quality standards, these components may demonstrate a great deal of inconsistency in performance.

Given the unpredictability in transceiver performance, the test data shows conclusive evidence that the use of category 6 cabling systems improves network performance and system reliability. Test results show more than a 13x reduction in the number of CRC errors using category 6 cabling.

Changing the cabling system to category 6 improves the signal-to-noise ratio of the entire transmission system allowing the receivers to more consistently and accurately receive the Ethernet packets. The improved static performance of category 6 cabling improves the overall reliability of network. This additional headroom allows the use of network components that might otherwise cause significant network downtime and expense.

Data Communications Competence Center

Nexans' Data Communications Competence Center, located at the Berk-Tek Headquarters in New Holland, Pennsylvania, focuses on advanced product design, applications and materials development for networking and data communication cabling solutions. The Advanced Design and Applications team uses state-of-the-art, proprietary testing and modeling tools to translate emerging network requirements into new cabling solutions. The Advanced Materials Development and Advanced Manufacturing Processes teams utilize sophisticated analytical capabilities that facilitate the design of superior materials and processes. The Standardization and Technology group analyzes leading edge and emerging technologies and coordinates data communication standardization efforts to continuously refine Nexans' Technology Roadmap. An international team of experts in the fields of cable, connectors, materials, networking, standards, communications and testing supports the competence center. The competence center laboratories are a part of an extensive global R&D network that includes eight competence centers, four application centers and two research centers dedicated to advanced technologies and materials research.