

JACK ASSEMBLY INSTRUCTIONS

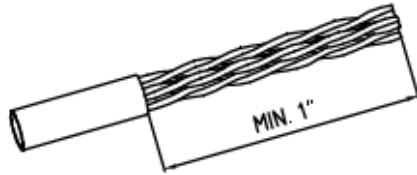

STEP 1:

Strip off at least 1 inch of jacket from end of cable.

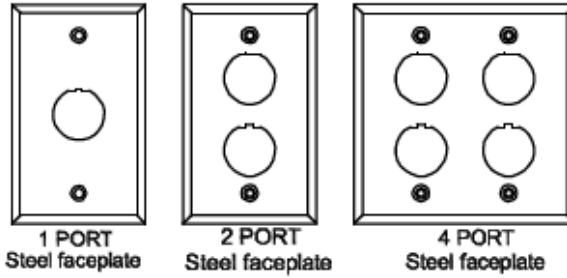
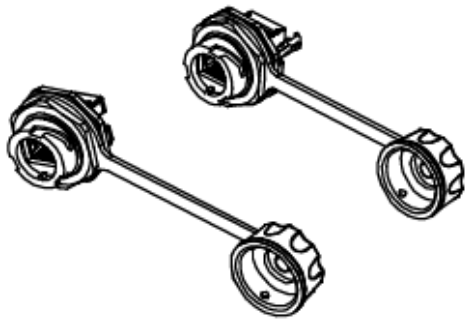
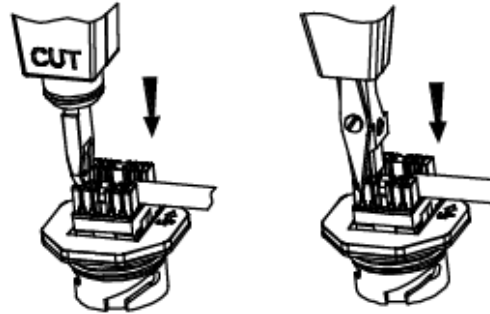

STEP 2:

Insert wires into IDC's according to the desired wiring configuration (T568B/T568A). Terminate wires using punch down tool. Make sure the tool is set to trim excess wire as shown.

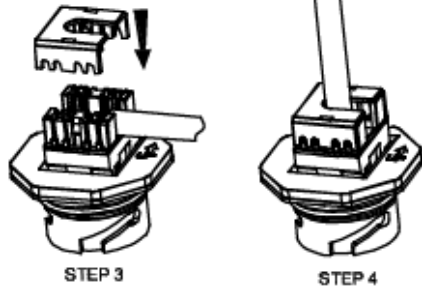

STEP 3:

Place termination cap on jack and press cap to make sure it is fully seated.

STEP 4:

Adjust the cable to a suitable position in the opening of the cap.

Additional steps below are for FTP Products:

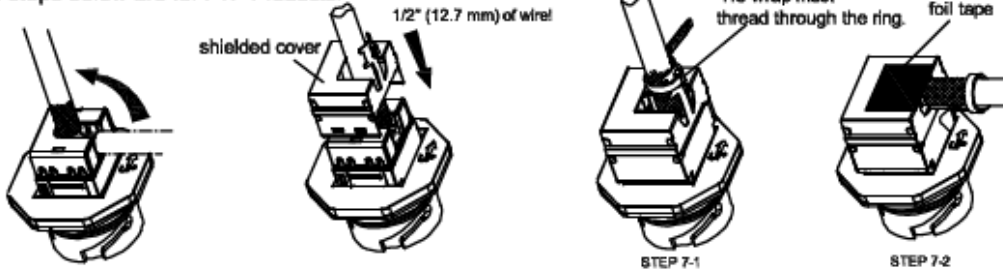

STEP 5:

Adjust cable to a position parallel to the axis of the jack so that the shield cover can snap onto the jack properly.

STEP 6:

Slide the shield cover down onto the jack until it snaps onto the jack shield.

STEP 7:

7-1 Thread the tie wrap through the ring on the shielded fin as show and tie it firmly. Do not crush the cable! Trim off excess.

7-2 Bend the cable perpendicular to the jack and secure the foil tape over the opening in the cover as shown.

JACK ASSEMBLY INSTRUCTIONS

